

# Touch-Free Silver Dispenser Stand for Hand Sanitiser

## PRODUCT DESCRIPTION

Stylish dispenser stands to promote hand sanitising.

## SECTORS

- Office & Facility
- Healthcare
- Public Facilities
- Industrial
- Food
- Hospitality
- Education

## TO BE USED WITH SC JOHNSON PROFESSIONAL® TOUCH-FREE DISPENSERS:

- IFSTF2EN
- TF2CHR
- TF2BLK
- TF2WHI
- TF2CLR

STOCK CODE	COLOUR	QTY/CASE	CASE DIMENSIONS
INFOFLDISP	Silver	1	75mm x 490mm x 710mm



Dispensers sold separately

## FEATURES

Easy to assemble (only 5 parts, assembly tools included)

Optional signage to customise the header with your message or logos (template provided)

Sturdy metal construction

Durable coating to protect against wear and tear

Use included silver metal catch tray or black/white plastic catch trays (sold separately)

Low profile base to maximise stability

Lightweight and easy to carry when cleaning the facility

SC Johnson Professional® dispenser sold separately

## TF Dispenser Stand Dimensions

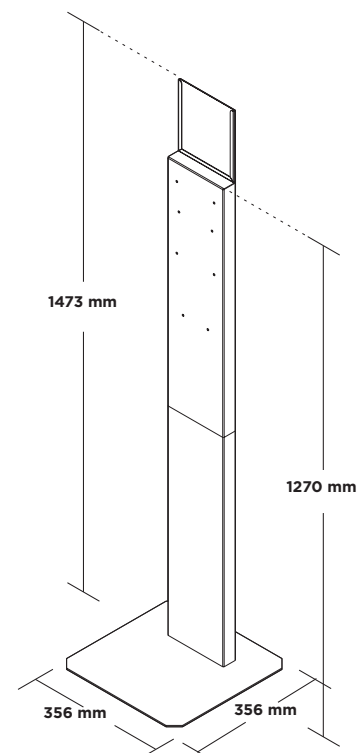

# Touch-Free Silver Dispenser Stand for Hand Sanitiser

## DESIGN YOUR OWN HEADER TEMPLATE

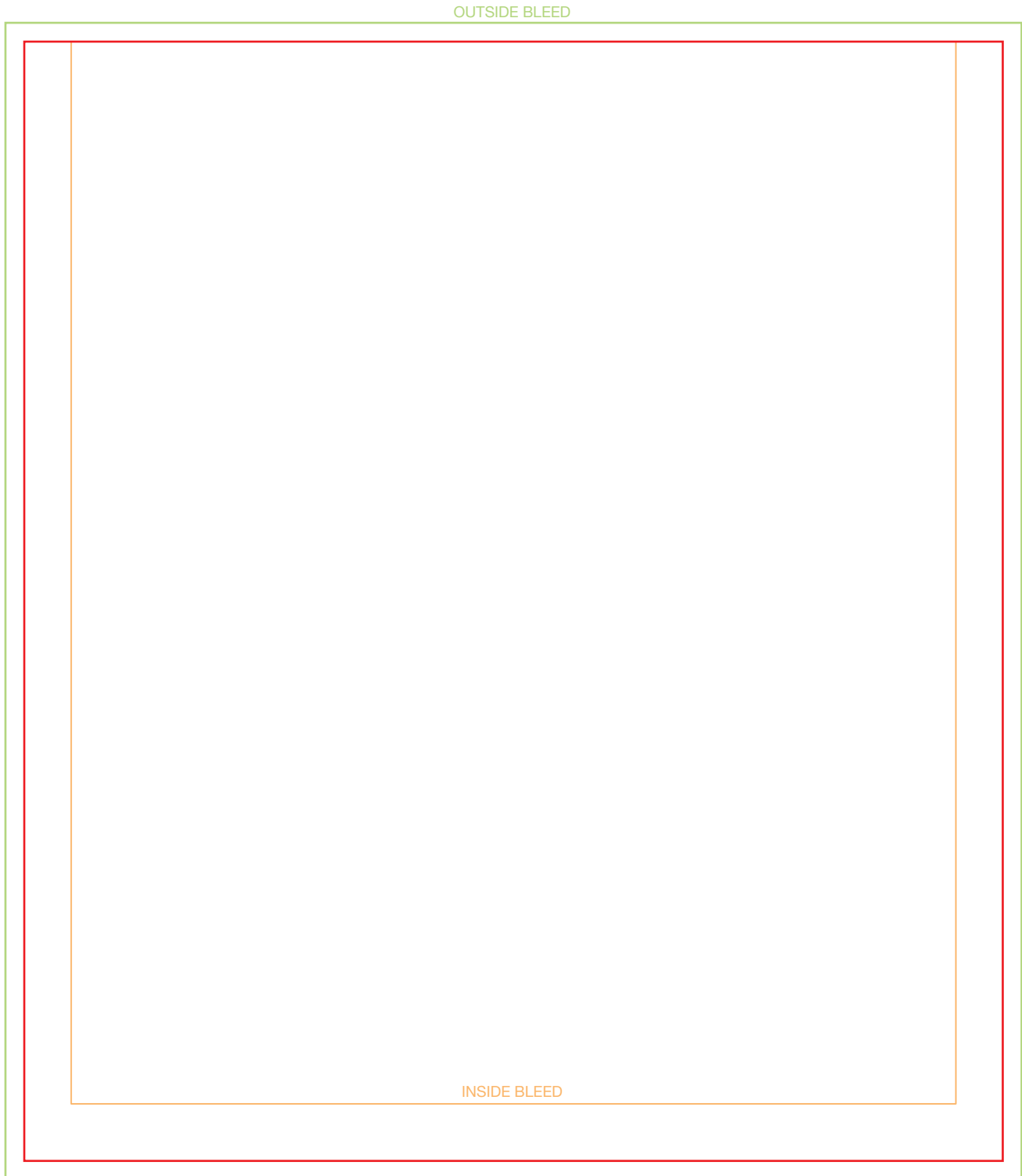

<b>PRINT AREA:</b>	171.45mm x 195.28mm
<b>TRIM/DIE SIZE:</b>	165.10mm x 188.93mm
<b>SUBSTRATE:</b>	0.25mm GLOSS LITHO STOCK

# Touch-Free Silver Dispenser Stand for Hand Sanitiser

## SANITISING STATION ASSEMBLY INSTRUCTIONS

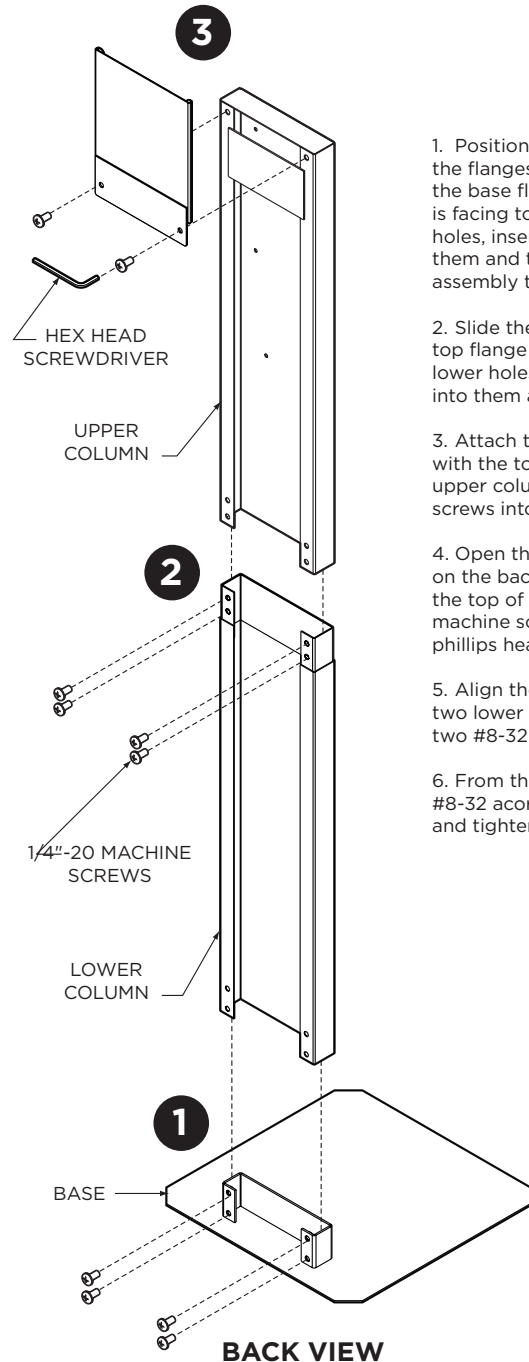
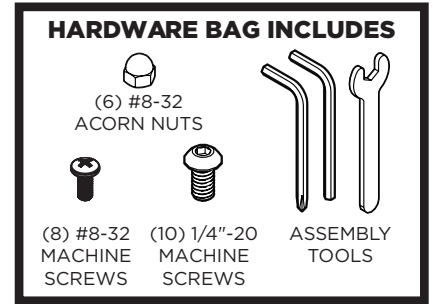

1. Position the base in the desired location with the flangeside up. Slide the lower column over the base flange so the open face of the column is facing towards the back. Align the four lower holes, insert four 1/4"-20 machine screws into them and tighten fully using the hex head assembly tool provided.

2. Slide the open end of upper column over the top flange of the lower column. Align the four lower holes, insert four 1/4"-20 machine screws into them and tighten fully.

3. Attach the header by aligning its two holes with the top two holes on the back of the upper column. Insert two 1/4"-20 machine screws into them and tighten fully.

4. Open the dispenser. Align the top four holes on the backplate with the top four holes at the top of the upper column, insert four #8-32 machine screws and tighten fully with the phillips head assembly tool provided.

5. Align the two holes in the drip tray with the two lower holes on the upper column, insert two #8-32 machine screws.

6. From the back of the unit, attach the #8-32 acorn nuts to the #8-32 machine screws and tighten down with the wrench provided.

